

Front Suspension
Anti Roll Bar:

- 2.2mm Green
- 2.3mm White
- 2.4mm Blue
- 2.5mm Yellow

Steering System:

- Swing Rack
- Bellcrank Rack

Bumpsteer Washers: _____

Camber: _____

Caster: _____

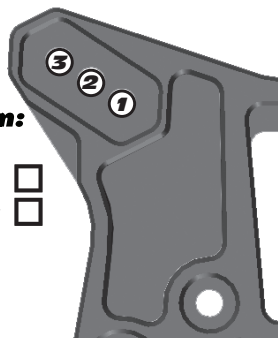
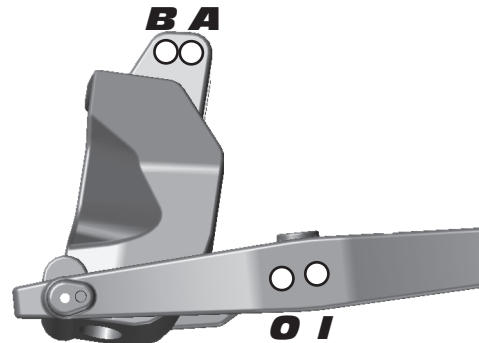
Toe: _____

Upper Hinge Pin Bushing

Front # _____
 Up Down

Rear # _____
 Up Down

B-Plate Type

Low Original

Kickup Bushing A-Plate

 Up Down

Ride Height: _____

Rear Suspension
Anti Roll Bar:

- 2.5mm Green
- 2.6mm White
- 2.7mm Blue
- 2.8mm Yellow

Wheelbase:

- Long
- Medium
- Short

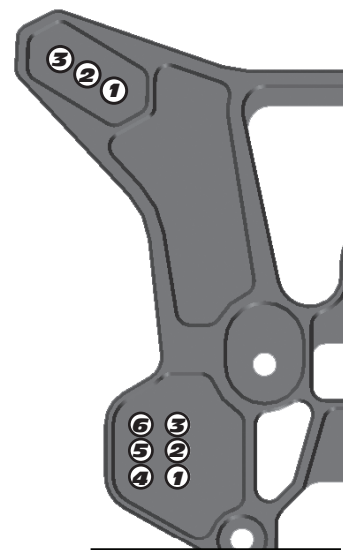
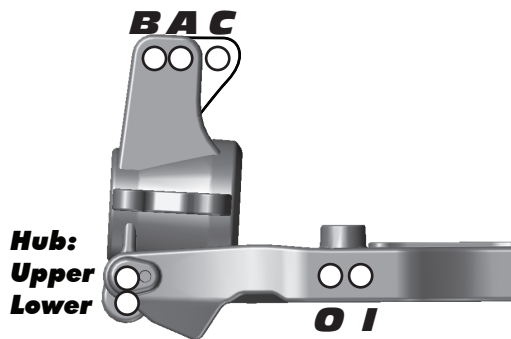
Camber: _____

Toe Bushing D-Plate

 In Out

Squat Bushing C-Plate

 Up Down

Hub: _____
 Upper _____ Lower _____

Ride Height: _____

Front Shocks

Spring: _____ **Shock Cap:** _____

Shock Fluid: _____ **Length:** _____

Piston: _____ **Rebound:** _____

Rear Shocks

Spring: _____ **Shock Cap:** _____

Shock Fluid: _____ **Length:** _____

Piston: _____ **Rebound:** _____

Chassis Braces / Wheel Hex

- Chassis Braces:**
- Pivot
 - Molded
 - Aluminum
- Wheel Hex:**
- Standard
 - Narrow

Chassis Weight

Weight: _____

Rear Hubs

- Rear Hubs:**
- Standard
 - CNC FT Alum.

Differentials

Front Diff Fluid: _____

Center Diff Fluid: _____

Rear Diff Fluid: _____

Notes: _____

Body / Wing

Body Type: _____

Wing Type: _____

Gap to Tower (MM): _____

Gearing

Spur Gear: _____

Pinion: _____

Motor / ESC / Batteries

Motor & Wind: _____

ESC: _____

ESC Setting: _____

Batteries: _____

Tires

Tire (F/R): _____ / _____

Compound (F/R): _____ / _____

Inserts (F/R): _____ / _____

Wheel (F/R): _____ / _____

Notes: _____

Radio / Servos

Radio: _____

Steering Servo: _____ **Steering Expo:** _____

Brake Expo: _____

Initial Brake: _____ **Drag Brake:** _____

Dual Rate: _____

Race and Vehicle Comments

Qualify: _____ **Main:** _____ **Finish:** _____ **TQ:** _____

Comments: _____

Track Info

- Traction:** High Medium Low
- Surface:** Smooth Bumpy Blue Groove
- Soft Dirt Grass Clay Wet
- Astroturf Dusty Other: _____